

MULTIVALVE ELECTRONIC CONTROLLER WITH DEMAND RECALL

Service Manual



SYSTEMAX 2014

Table of Contents

<u>Item</u>	<u>Page</u>
Introduction and General Description	3
Front Panel View and Description.....	3
Modes of Operation	4
Front Panel Displays	6
Programming	9
Quick Programming Guide	10
Option Settings Overview	11
System Programming Chart	12
Sample Unit Programming Chart.....	15
Option Settings Programming - Detailed Information	17
Specifications	24
Input and Output Descriptions and Electrical Requirements	25
Controller Programming Worksheet	26
Enclosure Assembly Exploded View	28
Enclosure Assembly Parts List	29
Systemax Valve Wiring Diagram - Single Piston Valves.....	30
Systemax Valve Wiring Diagram - Dual Piston Valves	31
Systemax Valve Wiring Diagram - Diaphragm Valve Stagers.....	32
Troubleshooting	33

SYSTEMAX 2014

Controller Front Panel

Systemax 2014 Controller Description

The Systemax 2014 is a very flexible, state of the art, electronic valve control system. It is easy to install and use in a variety of commercial and industrial applications. The controller is remotely mounted in the vicinity of the softener / filtration system. It connects to each valve in the system by means of an interlock cable assembly. Using flow meter inputs, the controller determines the Service, Standby, or Regeneration status of each valve in the water treatment system. Auxiliary pumps, Chemical Feeders, and Alarms can also be controlled by the Systemax. Step by step programming guides the user to custom tailor the system to their exact specifications.

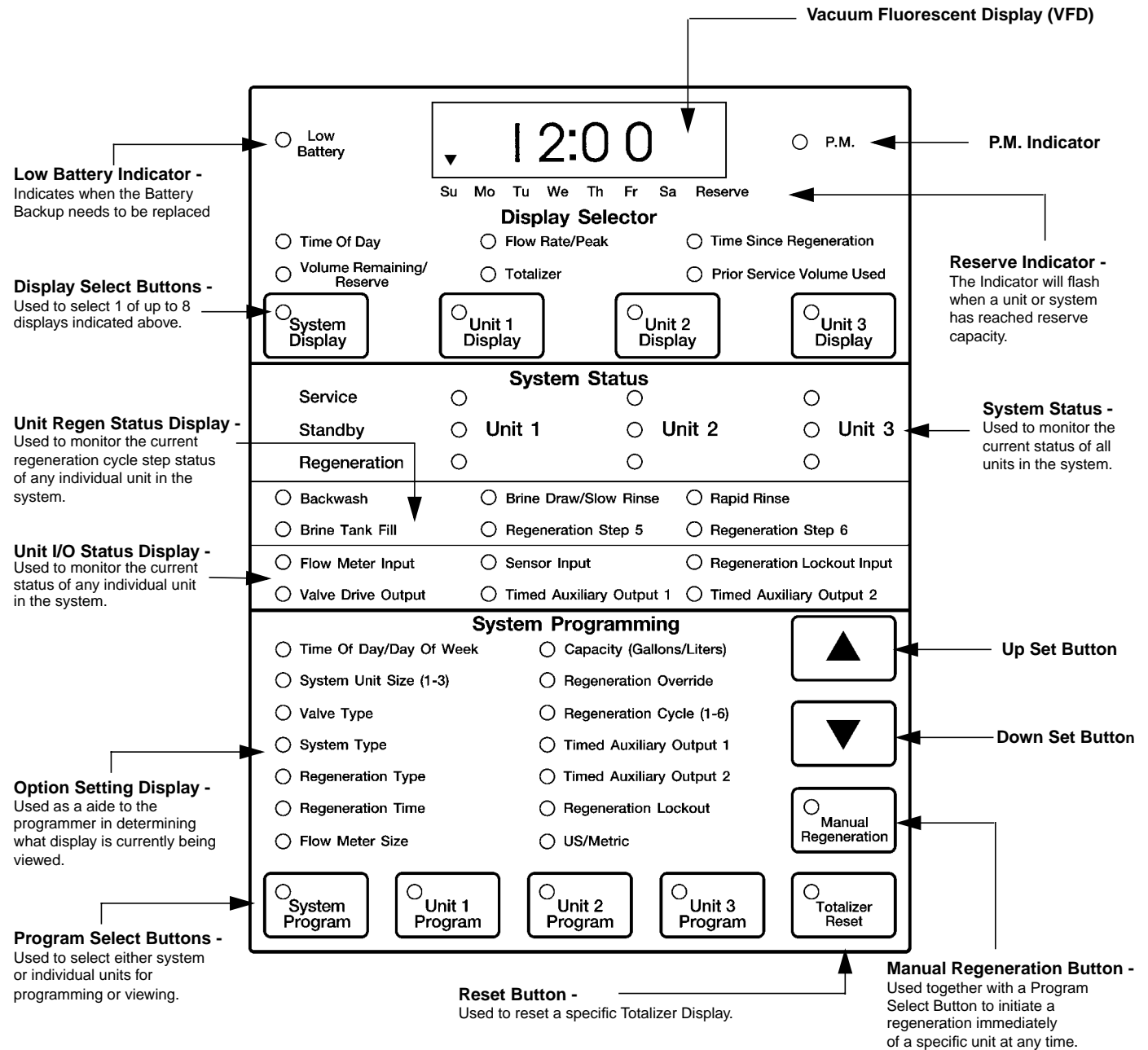

SYSTEMAX 2014

Controller Modes Of Operation

Start Mode

This mode is entered under any of the following three conditions:

1. AC power is restored with no battery backup installed or dead batteries.
2. The cpu resets due to power transients, malfunction, or the RESET button is pushed on the back of the display board.
3. A Front Panel Reset is initiated (System Display and Unit 3 Display buttons are pushed simultaneously for 25 secs.)

This mode is required by the controller for it to properly initialize and that all of the units in the system are returned to their home or service positions prior to the controller proceeding to the next mode of operation. The sequence of events is:

Time (Seconds)	Display	Function
1 to 4	[S rXX.Xd]	Start mode indicated by a flashing 'S'. Software revision displayed.
5	[JP2XXXXX]	Position of Hardware jumper JP2 displayed. (Factory Set)
6 to 55	[DISPLAY]	All indicator LED's are tested during this time by sequencing through a fixed pattern. It is during this time that the user may fast abort the Start Mode by simultaneously depressing the Totalizer Reset and System Display buttons. The abort will immediately go to the last 5 seconds of the Start Mode and then to the No Auto Regeneration Mode.
56	[XX CYCLE]	The AC Line frequency detected is displayed.
57 to 60	[S rXX.Xd]	The flashing 'S' and Software revision is displayed one more time. Note: If the non-volatile memory is corrupt this entire sequence will repeat once.
61 and up		If Power-on Reset Mode is programmed for AUTOrgEN, then the RESET mode is entered. If the mode is programmed for NO AUTO, then the No Auto Regeneration Mode is entered.

Reset Mode

This mode is entered after exiting the Start Mode with the Power On Reset Mode programmed for AUTOrgEN. (Automatic Regeneration). This mode will synchronize the entire system to the controller by resetting all capacities to their maximums and all in- service / standby statuses to a known state. Because of this re-synchronization, this mode will also automatically be entered after changing the System Unit Size, and/or the US/Metric setting in the programming mode. A lower case 'r' in the left most position in the Time of Day display and flashing LED's in the Manual Regeneration and System Program buttons will indicate that the controller is in the RESET Mode. After four minutes in this mode, the controller will proceed to regenerate each unit in the system one after the other starting with Unit #1 and on up. If the user wishes to immediately begin this series regeneration sequence, then a System Manual Regeneration should be initiated as follows: First press the Manual Regeneration button and then press the System Program button.

No Auto Regeneration Mode

This mode skips the automatic series regeneration of the Reset Mode. It restores the system to the last known state of the controller as saved in the non-volatile memory. (The controller status is saved upon exiting of programming or every hour, on the hour.) All system capacities, service, and standby states are restored. However, if a unit was in regeneration when the Start Mode was entered, then that unit will be placed back in regeneration at the start of the regeneration sequence. The time of day display will not be flashing to indicate that power was lost or the unit reset. The controller should be run through the RESET Mode at least once on initial startup before being programmed to this mode.

SYSTEMAX 2014

Controller Modes Of Operation Continued

Normal Operation Mode

In this mode the Time Of Day/Day Of Week Display will be typically viewed on the VFD. Other displays, Flow Rate, Peak Flow Rate, Volume Remaining, Reserve Capacity, Totalizer, Time Since Last Regeneration, or Prior Service Volume Used may also be viewed in this mode. Programming can be entered, the current time of day/day of the week changed, or manual regeneration initiated at any time.

The controller will immediately return to this mode after all other modes of operation have ended.

Controller Operation During Regeneration

The controller will continue to operate in a normal manner while a unit is in regeneration. Status displays for each unit in the system will be available at all times. The unit in regeneration however, will not be able to view its Time Of Day Display, instead it will display a Regeneration Display. This display will show the step # and the time left in that regeneration step in minutes and seconds [**2 - -100.25**]. The step # will also flash when the unit is between regeneration steps. After regeneration is complete the Time Of Day Display will return.

Controller Operation During Power Outage

During a power outage, the controller will continue to operate in a normal manner from a battery backup. The controller will keep all active data displays and memories up to date but will be unable to display them until line power is restored. The controller will delay the initiation of a regeneration cycle during a power outage and will not energize any outputs until line power is restored. Only the Low Battery LED will function. The controller will also not be capable of being programmed. Upon exiting of programming or every hour, on the hour, the controller will store into permanent memory the following displays, to be used upon power reapplication:

- | | |
|------------------------------|---------------------|
| 1. Time Of Day / Day Of Week | 3. Volume Remaining |
| 2. System Status | 4. Totalizer |

Program Mode

Whenever a Program Select Button is pushed, the controller will enter the *Program Mode* Provided that a unit is not in regeneration. In this mode the system or an individual unit program is set up by the operator. If the System Program Select Button is being used, pushing the Up/Down Arrow Buttons to adjust the setting will cause the identical value to be programmed into all units of the system. The programmer can then custom tailor individual valve programming by pushing a specific units Program Select Button and setting options as necessary. While in this mode the controller will continue to operate the system in a normal manner.

The controller will guide the programmer through all the necessary settings by displaying only valid option combinations.

Front Panel Displays

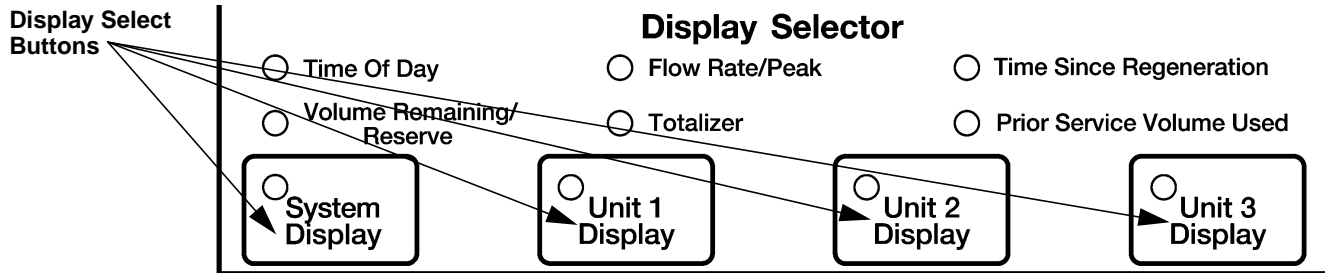

Up To Eight Displays May Be Viewed On The VFD By Pushing The Desired Unit's Display Select Button

Time Of Day / Day Of Week Displays

The current time of day is displayed as four digits, with hours and minutes separated by a flashing decimal point. An indicator arrow will show the current day of the week. Time of day may be 12 or 24 hour. If this display is flashing, then the unit has gone through the Reset Mode. Press any key to stop the flashing.

Volume Remaining / Reserve

The Volume Remaining Display is used to view the current volume of treated water available, including reserve. The volume unit used will be gallons or liters, depending on the US/metric setting. The maximum value of this display is determined by the current Capacity option setting. Whenever the Volume Remaining Display reaches the reserve capacity or a Sensor Input has received a signal, the reserve indicator arrow will begin to flash on the VFD.

A second display, *Reserve*, is used to view the current calculated reserve capacity for that unit or system. An (r) located in the leftmost display digit will indicate this second display. There will not be a reserve display with any immediate regeneration types.

Flow Rate / Peak

The Flow Rate Display is used to view the rate of treated water usage. The current flow rate will be displayed up to 999.9 volume units per minute. The rate unit used will be gallons or liters per minute, depending on the US/metric setting. The current flow rate is determined by the elapsed time taken to accumulate a specified number of pulses from the flow meter.

A second display, *Peak Flow Rate*, is used to view the maximum flow rate recorded since the unit was powered up, or midnight on Sunday. The letter (P) located in the leftmost display digit will indicate this second display.

Totalizer

The Totalizer Display records the total amount of water treated by the system. The display will reset to zero when 100 million is reached. The volume unit used will be gallons or liters, depending on the US/metric setting.

Time Since Last Regeneration

The Time Since Last Regeneration Display records the number of days and hours since the last regeneration of selected unit/system.

Prior Service Volume Used

The Prior Service Volume Used Display records the volume of treated water used between the most recent regeneration and the second most recent regeneration. The volume unit used will be gallons or liters, depending on the US/metric setting.



Controller Status Indicators

Active At All Times For All Units In The System.

(A) Low Battery Indicator

A red LED to the left of the VFD is used to indicate that the battery backup needs to be replaced.

(B) P.M. Indicator

A green LED to the right of the VFD is used as a P.M. indicator. This LED will only be active in US Mode.

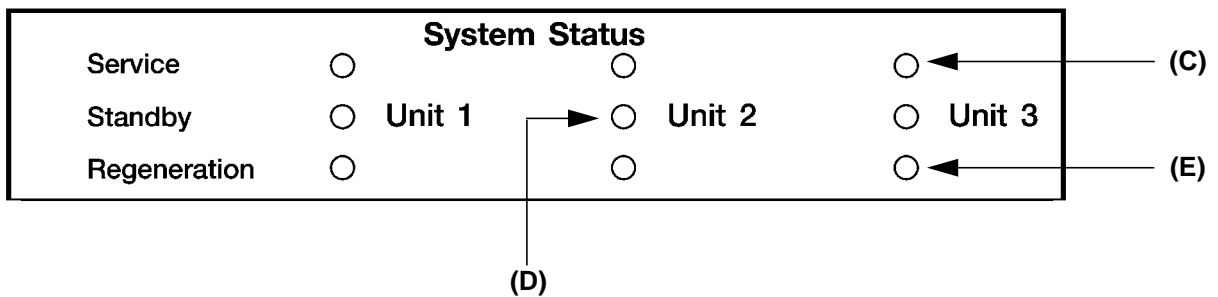

System Status Indicators

Active At All Times For All Selected Units In The System.

(C) Service Indicators -

A green LED is used to indicate that a unit is in Service.

A *flashing* green LED is used to indicate that a regeneration is pending or a unit is leaving Service for Regeneration.

(D) Standby Indicators -

A green LED is used to indicate that a unit is in Standby.

A *flashing* green LED is used to indicate that the unit is leaving Standby.

(E) Regeneration Indicators -

A green LED is used to indicate that a unit is in Regeneration.

A *flashing* green LED is used to indicate that the unit is leaving Regeneration.

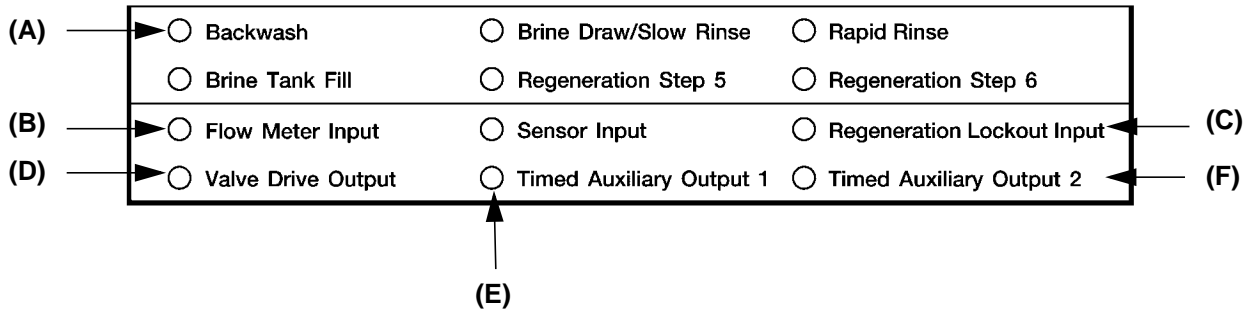

Unit Status Indicators

Activated by pushing the desired unit's Display Selector Button.

(A) Regeneration Cycle Status Indicators

A green LED is used to indicate which step of regeneration cycle a specific unit is in.

(B) Flow Meter Input Indicator

A green LED will flash at the rate pulses are being received by the controller from a flow meter.

(C) Regeneration Lockout Indicator

A yellow LED is used to indicate that a Regeneration Lockout Input Signal is being received from the unit number selected. This LED will flash (per set Minimum Signal Time) until the received signal is considered valid, then stay on until the signal is removed. This LED will be active only with the Regeneration lockout Option selected.

(D) Valve Drive Output Indicator

A green LED is used to indicate that a Valve Drive Output Signal is being sent to the unit number selected.

(E) Timed Auxiliary Output #1 Indicator

A green LED is used to indicate that this unit's output is active.

(F) Timed Auxiliary Output #2 Indicator

A green LED is used to indicate that this unit's output is active.

Brightness Correction Display:

Everyday at 3:00 A.M. the control will turn on the full VFD. As a result, all digits, dots, and arrows will be brightly displayed for 10 minutes. This feature is used to keep the display uniformly bright throughout its operational life. The controller will continue to function in the background normally during the duration of this display. Normal display operation will return automatically after this period of time is over or if any button is pushed.

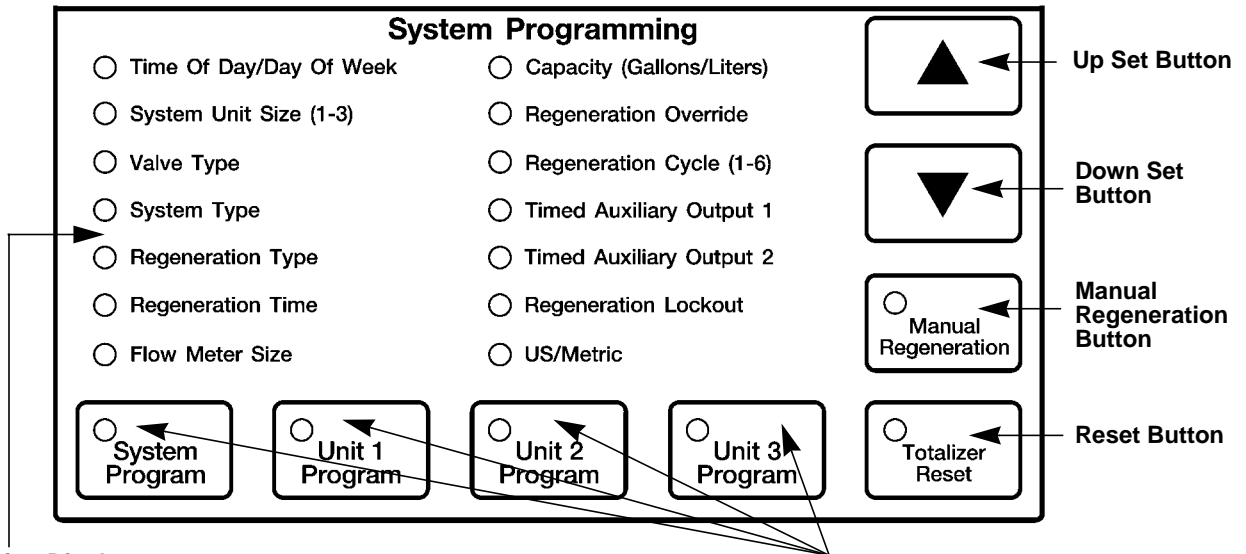

Option Setting Display -

Used as an aide to the programmer in selecting the desired display to be programmed. A LED indicator will turn on next to the current display being viewed.

Program Select Buttons -

Used to program system or individual unit operation using up to 33 different option setting displays indicated above by LEDs

Program Select Buttons

In normal operation these buttons are used by the user to enter the *Program Mode*, instruct the controller to manually initiate a regeneration of a unit, or reset a specific Totalizer Display. In the *Program Mode* various option settings are viewed and or set by pushing the desired units (or System) Program Select Button once per display until the desired one is viewed. Pushing the active Program Select Button after viewing the last option setting will exit the user from this mode.

If the Program Lockout feature is active, the programmer will have to push and hold the desired Program Select Button for a preselected amount of time before access is granted to System/Unit programming.

Set Up and Set Down Buttons

These two buttons are used to set all adjustable display values as desired. When the Up Arrow Button is pushed the display will increase in value. When the Down Arrow Button is pushed the display will decrease in value.

When either button is pushed and held, the display value will change slowly at first and then slowly increase (or decrease) in speed until a maximum speed is reached.

Manual Regeneration Button

This button is used to manually initiate an additional regeneration of the system or unit. When a Unit # Program Select Button is selected after pushing this button, a regeneration cycle of that unit is immediately initiated.

When the System Program Select Button is pushed after selecting this button, the controller will automatically determine which unit will initiate a regeneration cycle immediately. This decision will be based on current system status as well as the current option settings.

This button will be ignored with one unit already in Regeneration.

When pushed, this button will light up until the regeneration cycle is complete.

SYSTEMAX 2014

Controller Programming Continued

Stepping A Unit Through A Regeneration Cycle

Pushing the Program Select Button of a unit in regeneration will instruct the controller to advance the unit immediately to the next regeneration cycle step. By repeating this procedure each unit in the system can be stepped through its full regeneration cycle.

The user may advance or reverse the time remaining within a regeneration cycle step by pushing either the Set Up or Set Down Button until the desired time remaining appears. Regeneration cycle programming will not be changed and normal step timing is resumed.

Totalizer Reset Button

This button is used to reset the system's or individual unit's Totalizer Display. This display is reset by first selecting the Totalizer Reset Button then pushing and holding for 25 seconds the desired units Program Select Button. The desired units Program Select Button LED will flash rapidly during this 25 seconds then turn off once the display is reset. On a single flow meter system, the System Program Button must be held.

Quick Programming Guide

As an aide to the programmer, the controller will guide the programmer to which option settings need to be set, or can be set, for the numerous types of systems available.

#1 Set all option displays contained under System Program Select Button.

#2 Exit System Programming. All system settings will be automatically duplicated and stored in each individual units program. Regeneration Cycle Steps #1 Thru #6 Option Settings, for example.

#3 Controller programming is complete at this point if all units are to have the same settings.

#4 If there needs to be differences in settings, custom tailor individual unit programming by adjusting any settings contained under a Units Program Select Button.

All controller programming is stored in permanent memory. In event of a power outage and battery backup failure, all programming will remain intact upon controller power up. There will be no need to reprogram the controller other than reset the present time of day.

SYSTEMAX 2014

Option Settings

The following option settings are used to program the controller. They can be viewed by pushing the Program Select Button for that unit or System, once per display setting until the desired one has been reached.

US/metric

This option is used to select 12 or 24 hour timekeeping, and gallon or liter volume units.

Time Of Day / Day Of Week

This option setting is used to set the current time of day and day of week

System Unit Size

This option setting is used to select the number of units in the system.

Valve Type

This option setting is used to select how a unit will operate in the system based on a specific type of valve.

Demand Recall System Parameters

This option setting is used to select the way the controller is to operate in a demand recall system.

Regeneration Type

This option setting is used to select the way the time to regenerate decision is to be made by the controller.

Regeneration Time

This option setting is used to set the regeneration start time for any Delayed Regeneration Type.

Flow Meter Size

This option setting is used to set the proper calibration of a Flow Meter Input.

Capacity

This option setting is used in calculations made by the controller in determining when to initiate a regeneration.

Regeneration Override

This option setting is used to force a regeneration to occur at a certain minimum frequency.

Regeneration Cycle Step Programming

This series of six option settings is used in creating a regeneration cycle program for each unit in the system.

Timed Auxiliary Output #1

This option is preset by the Demand Recall Mode to operate each unit's Timed Auxiliary Output #1 relay.

Timed Auxiliary Output #2

This option setting is used to set the turn on/off time for a unit's Timed Auxiliary Output #2.

Regeneration Lockout (RL)

When this option is selected, the controller will not let a unit go into regeneration until the signal being received at that units Regeneration Lockout Input is removed.

Program Lockout

When this option is selected, the controller will not let the user go into the Program Mode until the desired Program Select Button is pushed and held for a preselected amount of time before access is granted.

Power On/Reset Mode Select

This option determines how the controller operates after AC power is restored without battery backup.

SYSTEMAX 2014

System Programming Chart



System Programming Is Entered

(System Program Select Button is pushed once per display until exit)

<input type="radio"/> System Program	[- - - - -X]	US/metric (Set desired display code)
<input type="radio"/> System Program	[- -XX.XX--] [- - - - -X] ▼	Time Of Day / Day Of Week (Display to set current time of day) (Display to set current day of the week)
<input type="radio"/> System Program	[- - - - -X]	System Unit Size (2 - 3) (Display to set the number of units installed in the system)
<input type="radio"/> System Program	[- - - - -X]	Valve Type (Display to set display code for the type of valve(s) used)
<input type="radio"/> System Program	[1.XXX.X-14]	Demand Recall Parameters (Display to set first on/off line trip point) (Set flow rate in gal/liters)
Optional	[2.XXX.X-14]	(Display to set second on/off line trip point) (Set flow rate in gal/liters)
<input type="radio"/> System Program	[rd-XX-14]	(Demand Recall Delay Time) (Set in seconds)
<input type="radio"/> System Program	[- - - - - X]	Regeneration Type (Set desired display code)
Optional	[XX- - - - 10] (XX Flashes)	(Viewed only with #10 selected) (Set type of regeneration)
Optional	[1-S-XX.XX]	Regeneration Time (Set desired time of day for start of Regeneration Window #1) (Viewed only with delayed types of regeneration)
Optional	[1-E-XX.XX]	(Set desired time of day for end of Regeneration Window #1)
Optional	[2-S-XX.XX]	(Set time of day for start of Regeneration Window #2, if desired)
Optional	[2-E-XX.XX]	(Set time of day for end of Regeneration Window #2)

SYSTEMAX 2014

System Programming Chart Continued

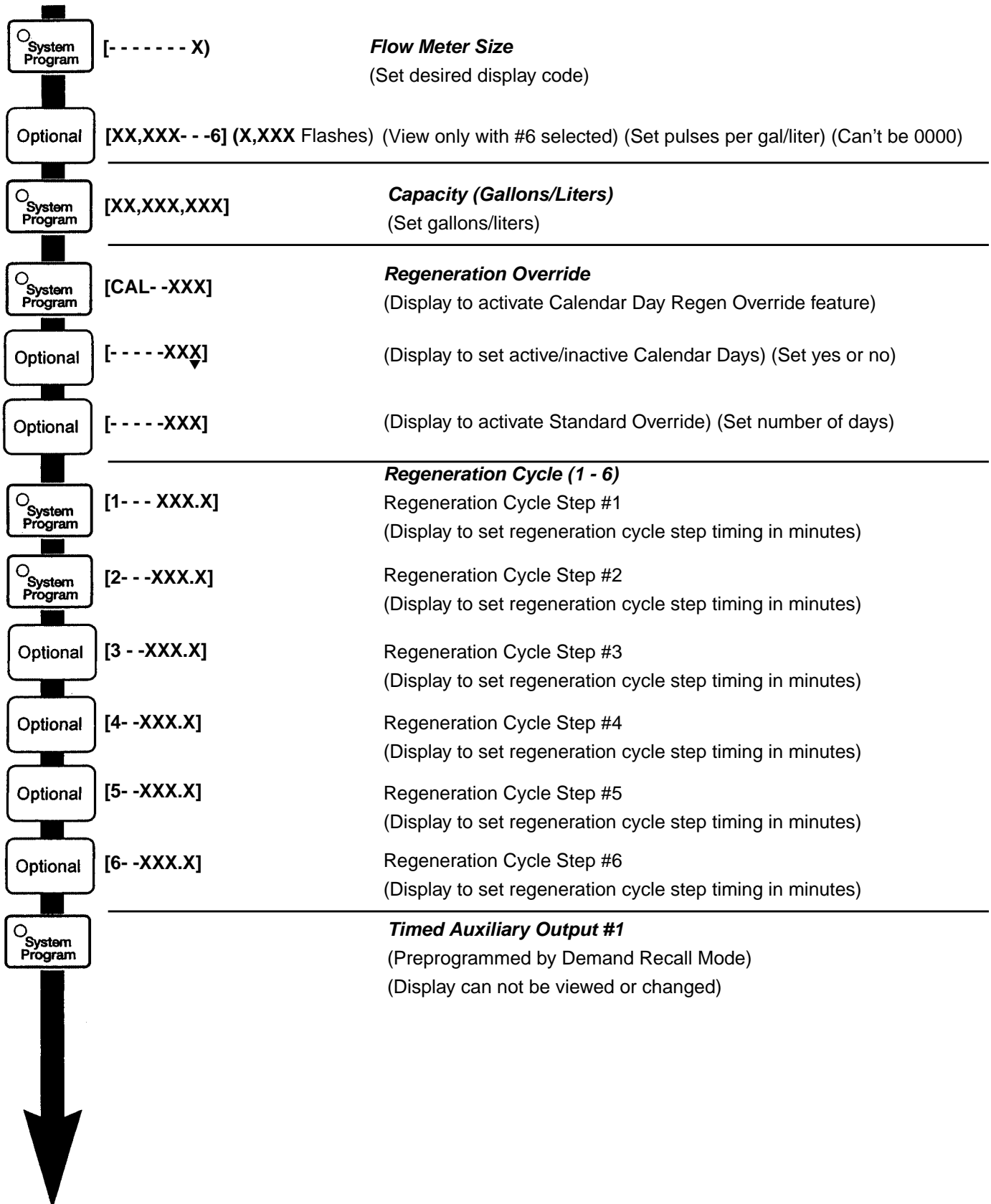

System Programming Chart Continued

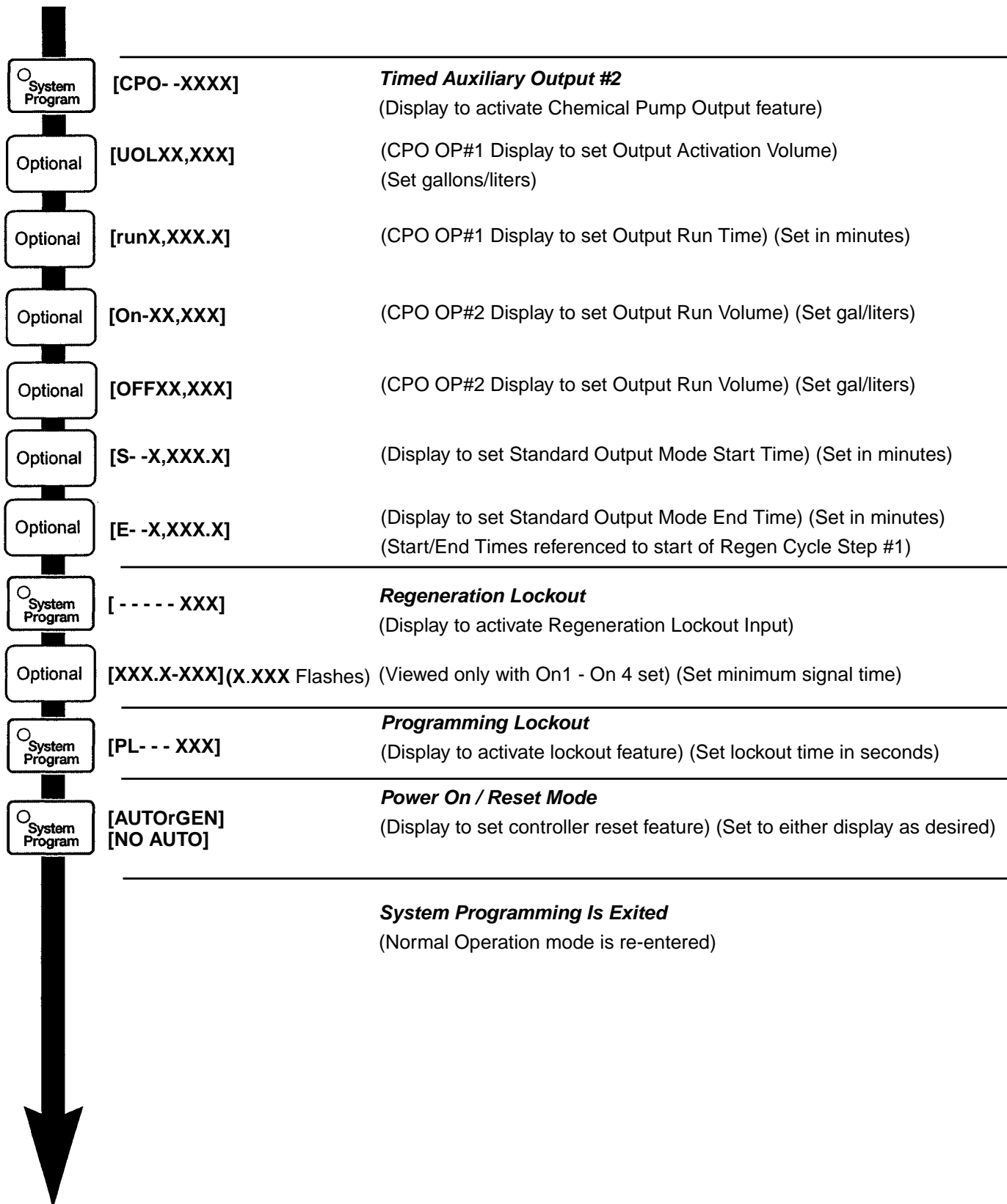

SYSTEMAX 2014

Sample Unit Programming Chart

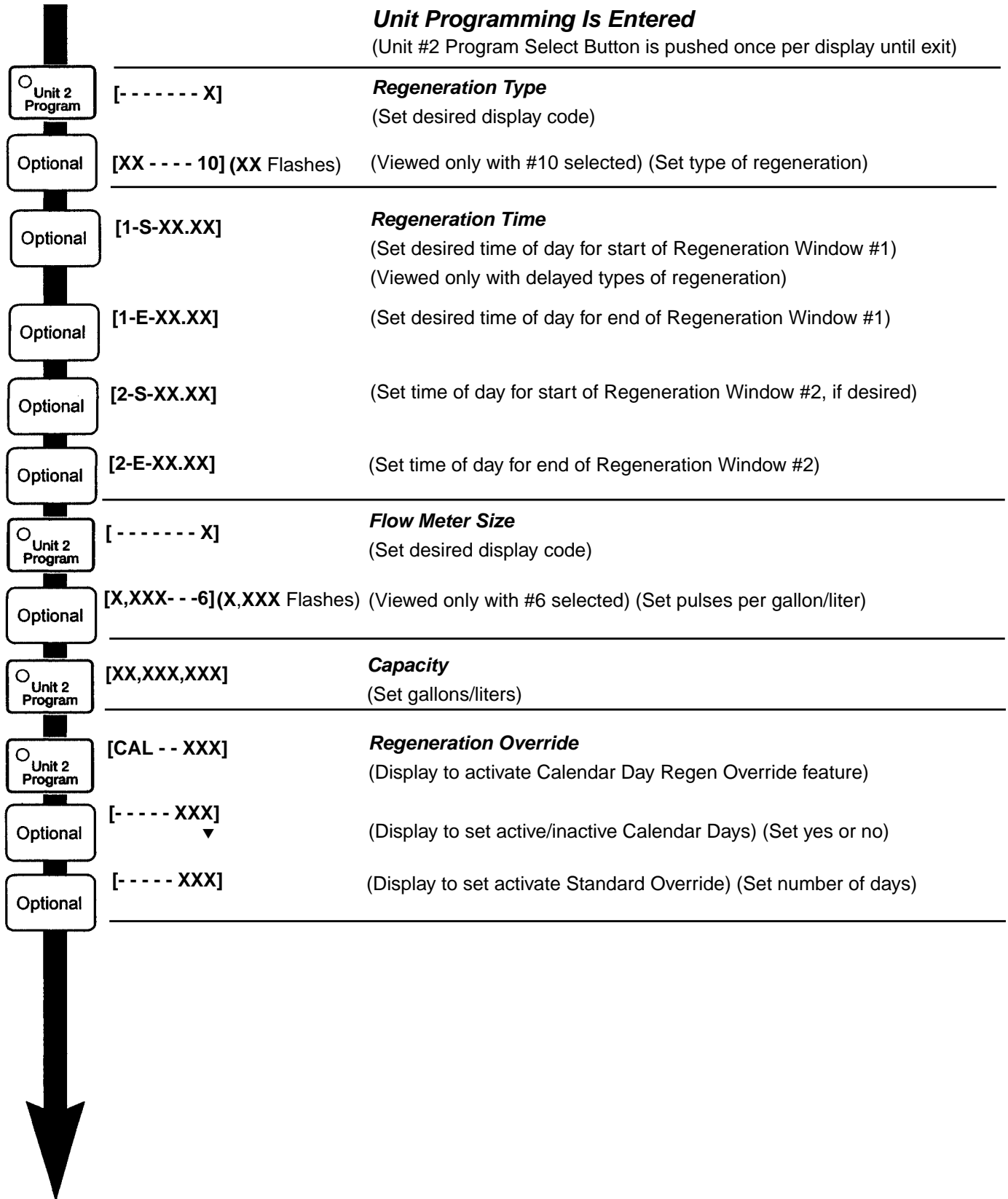

Sample Unit Programming Chart Continued

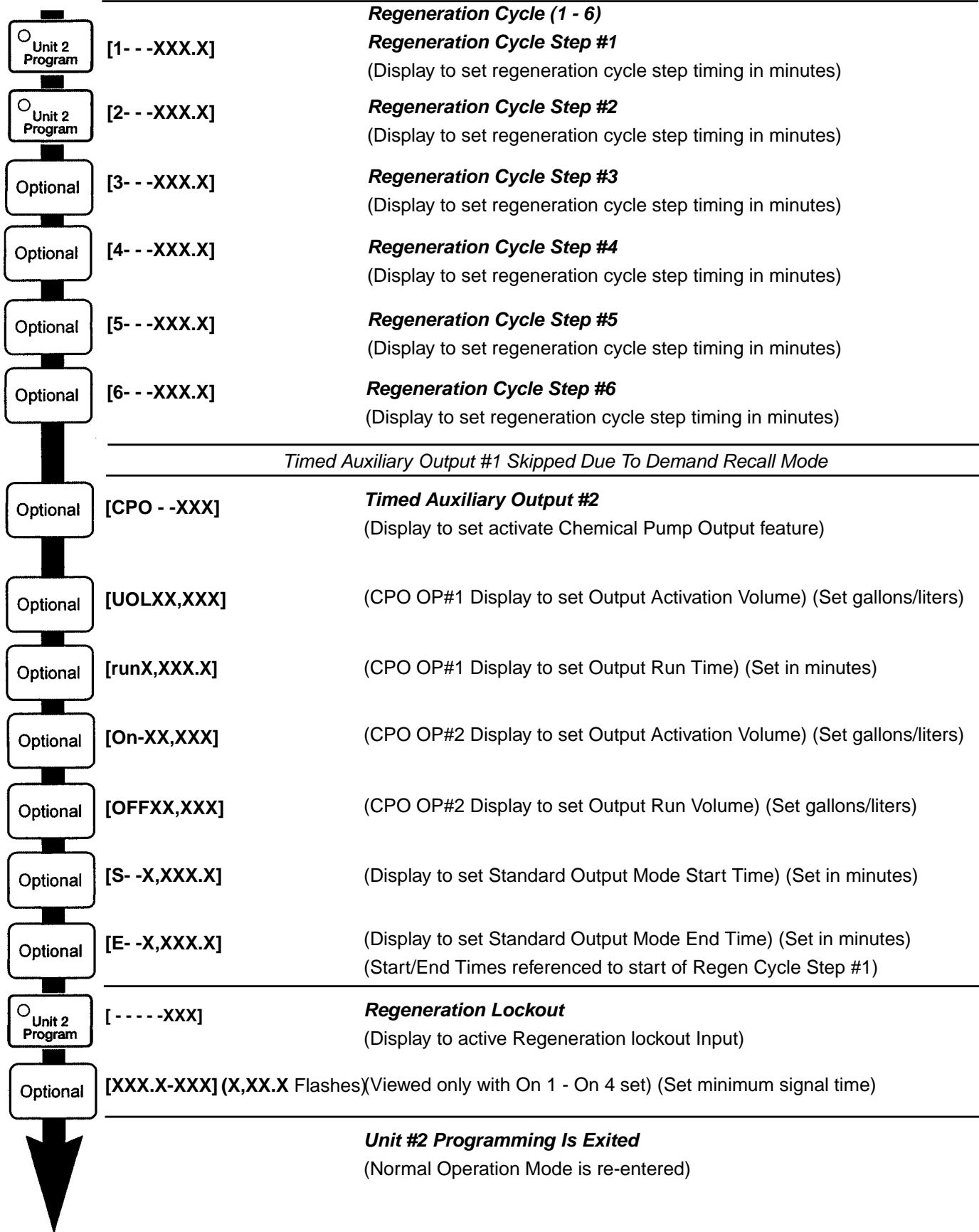

SYSTEMAX 2014

Option Setting Programming

The following option settings are available to be programmed by pushing either the Up or Down Set Button:

US/metric Option Setting Display

This option setting display has a one digit display with two settings:

- 1 - US Mode
- 2 - Metric Mode

With #1 set, the controller will use US units (gallons, g.p.m.) and a 12 hour timekeeping format.

With #2 set, the controller will use metric units (liters, l.p.m.) and a 24 hour timekeeping format.

Time Of Day / Day Of Week

This option setting consists of two displays. Display #1 sets the current time of day. Display #2 sets the current day of the week. Both displays may also be reset in normal operation by the Up/Down Set Buttons.

System Unit Size

This option setting informs the controller on the number of units to be operating in the system. This option setting has two settings, 2-3, which correspond to the number of units connected to the controller.

Valve Type

When this option is selected, the controller will configure itself to operate with one of 6 different types of valves. The options available and their display codes are:

- | | | |
|--|---|---|
| 1 - Standard Downflow Brining Valve(s)
"Butterfly Cam" Type Stagers | 3 - 2900/3900 Downflow Brining Valve(s)
4 - Diaphragm Valve Stager
("Notched Cam" Type) | 5 - Standard Upflow Brining Valve(s)
6 - 2900/3900 Upflow Brining Valve(s) |
| 2 - 9000/9500 Valve(s) | | |

When #1 or #5 is selected:

Systems with individual flow meters - The Volume Remaining Display will reset at the start of Regeneration and any Flow Meter Input signals received during Regeneration are ignored until the unit returns to Service.

When Valve Type #5 is set the default times for the Regeneration Cycle are changed and the regeneration cycle step indicator operation is modified.

When #2 is selected:

The Volume Remaining Display will reset at the start of Regeneration and any Flow Meter Input signals received from Regeneration through Service will be counted. The Lower Drive Input will be ignored.

When #3 or #6 is selected:

Systems with individual flow meters -The Volume Remaining Display will reset at the start of Regeneration and any Flow Meter Input signals received during Regeneration are ignored until the unit returns to Service.

The Lower Drive Input will be monitored at all times. A signal present at this input will indicate that the Lower Drive Valve is in a regeneration or standby position. The controller will not let another unit to go into regeneration or standby until this signal is removed. The controller will indicate that it is waiting for the Lower Drive Valve Signal to be removed by flashing either the Regeneration or Standby Status LED for that specific unit. A signal absent at this input will indicate that the Lower Drive Valve is in a service position. The controller will indicate that it is waiting for this signal to be sent by flashing the Service Status LED for that specific unit.

Option Setting Programming Continued

If the Lower Drive Input Signal is not removed within 60 seconds, (returning a unit to service) or received within 60 seconds, (sending a unit to regeneration or standby) a Lower Drive Error Message [**Ld Error**] will be scrolled across the VFD. Also, the Program Selector Button LED for the unit with the error will flash rapidly. Any calls for regeneration or of bringing units back into service will be delayed until this error is cleared. This is done automatically by removing the error condition. When Valve Type #6 is set, the default times for the regeneration cycle are changed, and the regeneration cycle step indicator operation is also modified.

When #4 is selected:

The Volume Remaining Display will reset at the start of Regeneration and any Flow Meter Input signals received during Regeneration are ignored until the unit returns to Service. The Lower Drive Input will be ignored. The controller will operate the stager in a normal manner with special cam (Home and Step Input) logic.

Demand Recall Parameters Option Setting Display

This option setting configures the controller for use in demand recall system. Three displays can be viewed. The first one will be used to set the minimum flow rate required to bring the next sequential Standby Unit back into Service (First Unit Recall Rate). The second display will be viewed only with 3 unit systems to set the minimum flow rate required to bring the second Standby Unit back into Service (Second Unit Recall Rate). The third display is used to set the minimum amount of time (in seconds) that the service flow rate is above or below the programmed recall rate before any action is taken. Display #2 can never be lower than display #1. Only one unit can be in regeneration at a time. The following displays will be able to be viewed with the System Display Selector Button:

1. System Flow Rate (Total of each individual units flow rates)
2. System Peak Flow Rate (Total of each individual units peak flow rates)

The System Flow Rate Display value is used to determine if the First and Second Recall Units will be placed into service or standby. This value will be the total of each service units individual flow rate.

Operation Of System #14 -Individual Meter Alternator Regeneration With Service Demand Recall - 2 Or 3 Units -The controller will operate as part of a multi-unit alternator regeneration system. Each unit in the system will have a active Flow Meter Input. Timeclock, and Sensor initiated regeneration will not be able to be used. Unit #1 will start in Service with #2, and #3 in Standby. Normally one unit is in Service at all times (Primary Service Unit). When the flow rate to the Primary Service Unit increases to a user specified rate, the next unit in sequence (First Recall Unit) will return to Service from Standby, and then as flow rate demand decreases return to Standby. With three unit systems, as flow rate demand increases past a second user specified rate, a third unit will be brought from Standby to Service and then as demand decreases back to Standby (Second Recall Unit). When the Primary Service Unit regenerates, the next unit in sequence will become the new Primary Service Unit and the following unit becomes the new First Recall Unit. As each units capacity is reached the controller will initiate a regeneration of that unit per the set Regeneration Type. Depending on the number of units in the system, flow rate demand, and the Primary Service Unit status, the regenerated unit will then be placed either into Standby or Service as the First or Second Recall Unit.

Regeneration Type Option Setting Display

This option setting has a display with a range of 2 to 10. There are 5 different regeneration options that can be selected by the user in this mode. The options to be available, and their option display codes, are shown below:

- 2 - Meter Immediate
- 3 - Meter Delayed with Standard Reserve
- 4 - Meter Delayed with Daily Variable Reserve
- 5 - Meter Delayed with Calendar Variable Reserve
- 10 - Manual Initiation

With Manual Initiation set, a second flashing display will be viewed. This single digit will flash until the number displayed is changed. This display is used to set the Regeneration Type Code # to be used in determining when to signal the user to initiate a regeneration of the system or unit.

SYSTEMAX 2014

Option Setting Programming Continued

Regeneration Type Decision Making -

<u>Option Code #</u>	<u>Description</u>
2	Meter Immediate - The controller will determine that regeneration is required when the available volume of treated water drops to zero. Regeneration to begin immediately.
3	Meter Delayed with Standard Reserve - The controller will determine that a regeneration is required when the available volume of treated water drops to or below the reserve capacity. The reserve capacity is automatically calculated at 1/3 the total capacity of the unit/system. Regeneration to begin at the set Regeneration Time.
4	Meter Delayed with Daily Variable Reserve - The controller will determine that a regeneration is required when the available volume of treated water drops to or below the calculated reserve. This reserve is based on water usage patterns for the previous 48 hours. Regeneration is to begin immediately at the set Regeneration Time.
5	Meter Delayed with Weekly Variable Reserve - The controller will determine that a regeneration is required when the available volume of treated water drops to or below the calculated reserve. This reserve is based on water usage data stored from 6, 13, and 20 days prior. Regeneration is to begin immediately at the set Regeneration Time.
10	Manual Initiation - The controller will monitor treated water usage as per set Regeneration Type # and will flash the Manual Regeneration Button Indicator as well as the Program Select Button of the unit to be regenerated. The System Program Select Button will be flashing along with the Manual Regeneration Button. Regeneration is to be delayed, regardless of the see Regeneration Type, until initiated in a normal manner by the user. (Pushing the Manual Regeneration Button then the indicated Program Select Button of the depleted unit.) If Timed Auxiliary Output #2 Option is not set, the controller will also activate Timed Auxiliary Output #2 until the unit indicated is sent into regeneration.

Regeneration Time Option Setting Display

This option setting sets up to two separate regeneration launch windows. One or both may be used and can be made as narrow or as wide as desired. The setting displays are identical to the Time of Day Display except that the period will not be flashing. The first display **(1-S)** sets the start of Window #1. The second **(1-E)** sets the end of Window #1. The third **(2-S)** sets the start of Window #2. The fourth **(2-E)** sets the end of Window #2. Both windows will not overlap, they also can not cross midnight. The second window can be turned off by setting the #2 Start Window Display to OFF. The launch window set on initial installations will be from 2:00 A.M./14:00, to 2:30 A.M./14:30 only, depending on the US/metric setting. Regeneration will only occur automatically within one of these two windows. This option setting is skipped when the Regeneration Type selected is #2.

Flow Meter Size Option Setting Display

This option setting has a one digit display that will have a range of 0 to 6. There are seven different size options to choose from, each with a number code. The standard electronic meter sizes available and their option display codes are shown below:

0 - 3/8"	2 - 1.0"	4 - 2.0"	6 - Non-Standard Flow Meter
1 - 3/4"	3 - 1.5"	5 - 3.0"	

When #6 is selected, a four digit display with a range of 1 to 9,999 will appear at the far left of the VFD. These digits will flash until the number displayed is changed. This option setting display is used to enter the number of meter pulses generated per unit of volume (gallons/liters) by the non-standard meter. The display settings are set by using the Up or Down Set Buttons.

Capacity Option Setting Display

This option setting instructs the controller as to the maximum treatment capacity of the unit # or system being programmed, including any reserve. This set value is used as a starting point in a volume countdown, which becomes the Volume Remaining. The amount subtracted from Volume Remaining is based on the water flow that is sensed by the flow meter(s). A call for regeneration occurs when the Volume remaining falls below the set or calculated reserve capacity, or if there is no reserve, when the Volume remaining reaches zero, which is displayed as [- - - - -] The type of regeneration initiation will be based on the Regeneration Type Option Setting.

When Meter Delayed with Daily/Weekly Variable Reserve Option is set, this value is also used in calculating the reserve capacity of the unit being set. This option setting consists of one 8 digit display. Depending on the US/metric option setting, this display will be set in gallons or liters. The Volume Remaining Display will count down from this set capacity to zero.

Regeneration Override Option Setting Display

This option setting has nine different displays. Depending on the regeneration override type selected, two or eight different display settings will be viewed. All displays in this option setting can be viewed one at a time by pushing the appropriate Program Select Button once per display. The first display [**CAL - - YES**] is used to inform the controller whether the user would like to use the Calendar Override Feature. By pushing the Up or Down Arrow Buttons the three rightmost digits will alternate displaying yes or no. If set to yes, the following series of seven displays will then appear:

[- - - - - YES]
 ↓

The programmer will then select the days of the week that a regeneration should occur, regardless of water usage. The first display is the calendar setting for Sunday. By pushing the Up or Down Arrow Buttons, the two or three right most digits will alternate displaying yes or no. A yes setting will permit the control to initiate a regeneration cycle on that day, a no setting will skip this day. A setting display for each day of the week will then follow with the arrow moving one space to the right for each day setting.

If [**CAL - - YES**] is set to [**CAL - - - NO**] the controller will use the Standard Override Feature. This feature is used to select the amount of days (24 hour periods) that can pass before a regeneration should occur, regardless of water usage. This setting consists of a two digit display that has a setting range of 1 to 99 days.

A position between 1 and 99 will display OFF and be used to cancel this option setting. The Standard Override Type will not be able to be viewed or set if the Calendar Day Override Type is set above.

Timeclock Regeneration Type will require one of these two override types to be active in order to initiate a regeneration. With either Timeclock/Meter Delayed/Sensor Delayed Regeneration Types set, regeneration will occur only at the set Regeneration Time. With either Meter Immediate/Sensor Immediate Regeneration Types regeneration will occur immediately when the programmed amount of time has passed since the last regeneration cycle.

Regeneration Cycle Steps #1 thru #6 Option Setting Displays

This option setting consists of 6 separate displays. One display per regeneration cycle step. Each display has a setting range of 0 to 999.9 minutes with a resolution of 0.1 minute. Timing is to start after the drive motor has reached the next position, not at the start of the drive signal. An off position exists below 000.0 and above 999.9. It will be shown as the word OFF. It is used to skip a cycle step totally and return the unit immediately to Service or Standby. When 000.0 is set for a step, the controller will advance the valve to that cycle step but spend zero time in that step and go immediately to the next step. This setting is used in conjunction with a special Valve Program Cam to repeat certain regeneration cycle steps before returning to Service or Standby. At the end of the last set cycle step, the controller will advance the valve in regeneration back to Service or Standby.

SYSTEMAX 2014

Option Setting Programming Continued

Timed Auxiliary Output #2 Option Setting Displays

These can be used to turn on a chemical pump during service, or turn off/on pumps, lights, and sensors during a regeneration cycle. This option setting has two different groups of displays, Chemical Pump and Standard Output Groups.

The first display is used to inform the controller whether the programmer would like to use either Chemical Pump Output Feature. A [**CPO - - OP1**] or [**CPO - - OP2**] display setting will inform the controller which of these two Chemical Pump Output types is to be used and advance the programmer to the proper first and second Chemical Pump Group displays. The Chemical Pump Output types available are:

OP1 - Volume On / Time Off

OP2 - Volume On / Volume Off

When Chemical Pump Output Option #1 (OP1) is selected, the control will activate the Timed Auxiliary Output #2 immediately, for a set period of time, when the preset volume has been reached during Service. There can be an output from each unit.

By pushing the Up or Down Arrow Buttons the three rightmost digits will alternate displaying OFF, OP1, or OP2. If this display is set to OP1, the next 2 displays will appear as:

[**UOLXX,XXX**]

THEN

[**runX,XXX.X**]

This first display [**UOLXX,XXX**] is used to set the number of volume units that will be allowed to flow through the softener before the Timed Auxiliary Output #2 is activated. This setting has a range of 1 to 99,999 volume units. The second setting [**runX,XXX.X**] contains the Timed Auxiliary Output #2 Activation Run Time setting. This setting has a range of 0 to 9,999.9 minutes. Both option settings are adjusted by using the Up or Down Set Buttons. The volume count is reset at the activation of the output.

When Chemical Pump Output Option #2 (OP2) is selected, the control will activate the Timed Auxiliary Output #2 immediately, for the set amount of flow volume, when the programmed trigger volume has been reached during Service. There can be an output from each unit.

By pushing the Up or Down Arrow Buttons the three rightmost digits will alternate displaying OFF, OP1, or OP2. If this display is set to OP2, the next 2 displays will appear as:

[**On-XX,XXX**]

THEN

[**OFFXX,XXX**]

This first display [**On-XX,XXX**] is used to set the number of volume units that will be allowed to flow through the softener before the Timed Auxiliary Output #2 is activated (Output Activation Volume). This setting has a range of 1 to 99,999 volume units. The second setting [**OFFXX,XXX**] contains the Timed Auxiliary Output #2 Run Volume setting. This setting has a range of 0 to 99,999 volume units. Both option settings are adjusted by using the Up or Down Set Buttons. The volume count is reset at the activation/deactivation of the output.

When Standard Output Option (CPO--OFF) is selected, the Timed Auxiliary Output #2 will function as a Standard Output with one on/off time during Regeneration. The first and second Standard Output Group displays will then be able to be viewed and set.

Option Setting Programming Continued

Timed Auxiliary Output #2 Option Setting Displays Continued

This option setting consists of 2 displays, [S - X,XXX.X] [E - X,XXX.X] The first five digit setting [S - X,XXX.X] contains the Timed Auxiliary Output #2 Activation Start Time setting. This turn on time is referenced from the moment timing begins for Regeneration Cycle Step #1 as sensed by the Home and Step Switch Inputs. This setting has a range of 0 to 9,999.9 minutes. The second five digit setting [E - X,XXX.X] contains the Timed Auxiliary Output #2 Activation End Time setting. This end time is also referenced from the moment timing begins for Regeneration Cycle Step #1. This setting has a range of 0 to 9,999.9 minutes.

The controller will not allow an end time setting equal or less than the start time setting. A special setting [S - - - - OFF] below [S - 0,000.0] and above [S - 9,999.9] will cancel this option. There will be a special setting [E - - - - - S] below [E - 0,000.0] and above [E - 9,999.9] that is used in programming the output to turn off when the unit is returned to Service. In order for this to happen, the display setting would be set to [S - X,XXX.X] [E - - - - - S].

With Valve Types #1, #2, #4, or #5 set, there will be another setting below [S - 0,000.0] and above [S - 9,999.9] It will be shown as [S - - - - - F] It is used to activate this output *immediately* upon the unit entering regeneration, before Regeneration Step #1 begins. This feature will prevent any untreated water bleed-through while the units are transitioning in and out of service. Timed Auxiliary Output #2 settings will not be able to be viewed or set if Regeneration Type #10 is also selected.

Note: Timed Auxiliary Output #1 is automatically set to: [CPO - - OFF], [S - - - - - F], and [E - - - - - S].

Regeneration Lockout Option Setting Display

When this option is selected, the controller will not allow a system/unit to go into regeneration until the signal to that systems/units Regeneration Lockout Input has been removed. This option has five settings:

OFF	On1	On3
	On2	On4

OFF cancels this option.

On1 will not allow the control to initiate a regeneration of that unit. (Individual Lockout)

On2 is similar to On1, but will also activate Timed Auxiliary Output #2 until any button on the control is pushed.

On3 is similar to On1 except only the Regeneration Lockout Input for Unit #1 is active, but will lock out the whole system.

On4 is similar to On3, but will also activate Unit#1's Timed Auxiliary Output #2 until any button on the control is pushed.

Whenever this feature is active, a second flashing display will be viewed. This four digit display setting will flash until the number displayed is changed. This display is used to set the time, in minutes, a regeneration lockout signal must be received before a regeneration of the system or unit is initiated. A 000.0 setting will lockout a regeneration cycle immediately.

The settings On3 and On4 are used when one lockout signal is provided to prevent regeneration of any unit in the system. If an on time is set for Timed Auxiliary Output #2 then setting On2 or On 4 will not be viewed. A regeneration lockout signal must be removed for at least one minute before the lockout is actually cleared.

Program Lockout Option Setting Display (PL)

Then this option is selected, the controller will not allow the user to go into the *Program Mode* until the desired System/ Unit #s Program Select Button is pushed and held for a specified time. This option setting consists of one display. Setting the display to OFF will cancel this feature.

Setting the display to a specific number will activate this feature. This display has a range of 1 to 99 seconds and is used to set the minimum amount of time (in seconds) any Program Select Button must be pushed and held before the Programming Mode is entered. Regardless if this feature is active or not, exiting the Programming Mode will remain unchanged.

Unit Power On / Reset Mode

This setting determines the behavior of the controller after a reset or restoration of power. Use the Up/Down Arrow buttons to select between [**AUTOGEN**] and [**NO AUTO**]. With [**AUTOGEN**] selected, the controller will go through its normal power up sequence and then initiate, after a four minute delay, a System #6 style series regeneration of each unit in the system. The Time of Day display will be flashing until any button is pressed on the keypad. This is the indication that there was a total loss of power or a controller reset. Use this setting if a fully initialized system is required after power restoration.

With [**NO AUTO**] selected, the controller will go through its normal power up sequence and then restore the system to the conditions as last saved in non-volatile memory. If a unit was in regeneration, then only that unit will be set to repeat the entire regeneration cycle. Otherwise all units will be set to their last known service / standby status. The Time of Day Display will not be flashing. Actual times displayed and volumes remaining may not match actual system status. Use this setting if a controller has frequent reset problems or there are frequent power outages and a battery backup is not installed.

SYSTEMAX 2014

Specifications

Electrical Specifications -

Electrical Safety

The power supply to the controller must be unswitched and be fuse or circuit breaker protected at 15 A. All system wiring must be done in accordance to local electrical codes.

Recommended Operating Voltage

Input Voltage Tolerance: -20% and +10% of 120V, and 240V 50/60 Hz
-10% and +20% of 24V 50/60Hz

Recommended Maximum Operating Currents

1. Total System: 15A (Controller and all equipment powered through the controller)
2. Individual Units: 6.3A (Total of all units and controller not to exceed 15A)
3. Individual Relay Outputs: 6.3A at 250VAC (Total of all units and controller not to exceed 15A)
4. Total of all +5VDC Sensor Power Supply Outputs not to exceed .3A
5. Operating Current Of Controller Electronic Circuitry: 0.5A (Includes .3A Max. +5VDC Sensor P.S. Current)

Battery Backup

1. Battery Backup: Six "AA" size Alkaline Batteries
2. Minimum Battery Backup Time: Approximately 24 Hours (Using Six Alkaline Batteries At Full Capacity)
3. Depending on Flow Meter/Regeneration Lockout Input usage, battery type, and remaining battery Capacity, minimum battery backup time may vary.
4. Always install backup batteries with the control connected to line power.

Input Wiring

1. For best performance route all low voltage cables and devices (flow meters, etc.) away as much as possible from any sources of electrical interference (motors, switches, etc.).
2. Always wire SVO or Lower Drive to Timed Auxiliary Output #1 for each unit.

Environmental Specifications -

Controller Environmental Specifications

Enclosure NEMA 4X

Controller Ambient Operational Temperature Rating 0 - 70 degrees C.

Humidity Range of 0 to 95% non-condensing.

Controller Storage Temperature Rating -40 to +80 degrees C.

Storage Humidity Range of 0 to 95% non-condensing.

Installation in damp locations

Only the controller itself is installed a NEMA 4X enclosure, any equipment connected to it may not. Excessive moisture on all electrically powered equipment not designed for this environment may lead to erratic performance and premature failure of that piece of equipment and/or the controller. Please follow safe operating practices when installing and operating this equipment.

When local electrical codes require all wiring in Rigid Metallic conduit.

To preserve NEMA 4X rating, all interconnection wiring must be run through watertight conduit and fittings.

On initial installations during cold weather it is recommended that the installer warm the controller up to room temperature before operating.

Controller Input / Output Electrical Requirements

Home and Step Switch Inputs

Two inputs per unit. The controller monitors continuously two low voltage dc switch closure inputs for signals sent from each unit in the system. These signals are used by the controller to determine the present status of each system unit as well as to control valve drive motors properly through their Valve Drive Outputs. The Home Signal is only present when the unit is in service. The Step Signal changes state during a regeneration cycle. A Valve/Stager Homing and Program Cam are typically used to generate these signals. Anytime the Home Signal is lost for over one minute, with a valve in Service, the controller will indicate this problem by displaying an Upper Drive Error Message [**Ud Error**] in the VFD. Also, the Program Selector Button LED for the unit with the problem will flash rapidly. Any calls for regeneration or of bringing units back into service will be delayed until the error is cleared. This is done automatically by removing the error condition.

Lower Drive Input

One input per unit. The controller monitors continuously a low voltage dc switch closure input for signals sent from each unit in the system (Valve Type #3 and #6 Only). A signal present (switch closed) at this input will indicate that the Lower Drive Valve is in a regeneration or standby position. The controller will indicate that it is waiting for this signal to be removed by flashing either the Regeneration or Standby Status LED for that specific unit.

A signal absent (switch open) at this input will indicate that the Lower Drive Valve is in a service position. The controller will indicate that it is waiting for this signal to be sent by flashing the Service Status LED for that specific unit. If the Lower Drive Input Signal is not removed within 60 seconds, (returning a unit to service) or not received within 60 seconds, (sending a unit to regeneration or standby) a Lower Drive Input Error Message [**Ld Error**] will be viewed on the VFD. Also, the Program Selector Button LED for the unit with the problem will flash rapidly. Any calls for regeneration or of bringing units back into service will be delayed until the error is cleared. This is done automatically by removing the error condition.

Flow Meter Inputs

One input per unit. This input requires a Hall Sensor type solid state signal generator. This sensor is "wetted" with +5vdc from the controller. Signals sent to these inputs will inform the controller to increment or decrement all active volume related displays, which are determined by the Regeneration Type selected. As an indication of the current status of the Flow Meter Input, the controller will flash the Flow Meter Input LED once per flow meter pulse received by the controller.

Regeneration Lockout Input

One input per unit. This input requires a dry contact switch closure. This switch is wetted with +5vdc from the controller. A signal sent to one of these inputs will inform the controller to prevent the regeneration of that system/unit number. The Regeneration Lockout Input LED will flash from the moment Regeneration Lockout Input Signal has been received until the set minimum signal on time has been reached, and then remain on until the signal is removed.

Timed Auxiliary Output #1

One SPDT output per unit. The controller has the capability to drive either an AC or DC powered device for a specified period of time as set in the option setting Timed Auxiliary Output #1. The relay output is rated at 6 amps at 30 Vdc or 240Vac. The Timed Auxiliary Output #1 LED of the unit selected by its Display Selector Button will turn on when this output is active.

Timed Auxiliary Output #2

One SPDT output per unit. The controller has the capability to drive either an AC or DC powered device for a specified period of time as set in the option setting Timed Auxiliary Output #2. The relay output is rated at 6 amps at 30 Vdc or 240Vac. The Timed Auxiliary Output #2 LED of the unit selected by its Display Selector Button will turn on when this output is active.

Valve Drive Outputs

One SPDT output per unit. The controller has the capability to drive either an AC or DC powered device for a specified period of time as set in regeneration cycle programming. The relay output is rated at 6 amps at 30 Vdc or 240Vac. The Valve Drive Output LED of the unit selected by its Display Selector Button will turn on when this output is active.

SYSTEMAX 2014

Controller Program

Installation Site: _____

Installation Date: _____

Dealer Name / Phone No.: _____

Revision Number Of Program: _____

	System	Unit #1	Unit #2	Unit #3
US/metric	_____			
System Unit Size	_____			
Valve Type	_____	_____	_____	_____
System Type	14			
1ST Recall Rate Trip Pt.	_____			
2ND Recall Rate Trip Pt.	_____			
Recall Delay Time	_____			
Regeneration Type	_____	_____	_____	_____
(#10 Regeneration Type)	_____	_____	_____	_____
Regeneration Time -				
(Window #1 S/E)	_____	_____	_____	_____
(Window #2 S/E)	_____	_____	_____	_____
Flow Meter Size	_____	_____	_____	_____
(#6 Pulses Per Gallon/Liter)	_____	_____	_____	_____
Capacity	_____	_____	_____	_____
(Gallons / Liters)				
Regeneration Override -				
Calendar Day Override	Sun Mo Tu We	Su Mo Tu We	Su Mo Tu We	Su Mo Tu We
(Circle Override Days)	Th Fr Sa	Th Fr Sa	Th Fr Sa	Th Fr Sa

SYSTEMAX 2014

Controller Program (Cont'd.)

	System	Unit #1	Unit #2	Unit #3
Standard Override (Max. days in Service)	_____	_____	_____	_____
Regeneration Cycle (1-6) -				
Step #1 (Typically Backwash)	_____	_____	_____	_____
Step #2 (Typically Brine Dr/Sl Rinse)	_____	_____	_____	_____
Step #3 (Typically Rapid Rinse)	_____	_____	_____	_____
Step #4 (Typically Brine tank Fill)	_____	_____	_____	_____
Step #5 (Typically Cancelled)	_____	_____	_____	_____
Step #6 (Typically Cancelled)	_____	_____	_____	_____
Timed Auxiliary Output #1 -				
Standard Output				
(Start Time)	Fast	Fast	Fast	Fast
(End Time)	Service	Service	Service	Service
Timed Auxiliary Output #2 -				
Chemical Pump Output				
(Volume Act. Count - Gal / L)	_____	_____	_____	_____
(Output Run Time/Volume)	_____	_____	_____	_____
Standard Output				
(Start Time)	_____	_____	_____	_____
(End Time)	_____	_____	_____	_____
Regeneration Lockout	_____	_____	_____	_____
(Minimum Signal On Time)	_____	_____	_____	_____
Program Lockout	_____			
Reset Mode (Circle One)		Auto Regeneration On		
		Auto Regeneration Off		

SYSTEMAX 2014

Enclosure Assembly

(See Opposite Page for Parts List)

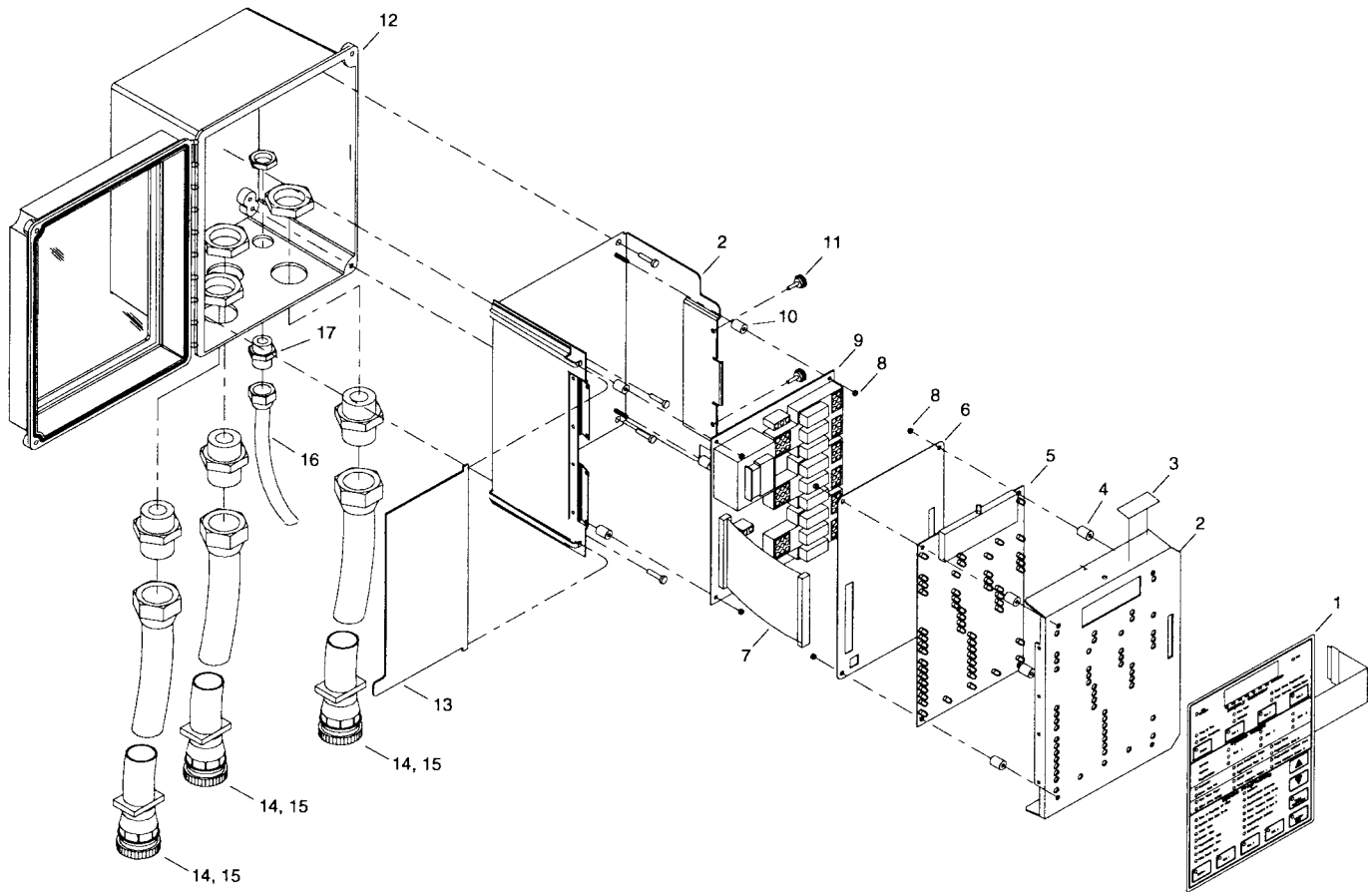

SYSTEMAX 2014

Enclosure Assembly

Parts List

Item No.	Quantity	Part No.	Description
1	1	18311	Assembly, Switch Pad
2	1	18577	Assembly, Enclosure Bracket
3	1	19049	Label, Serial Number
4	4	18293	Spacer, Nylon
5	1	18715-14	Circuit Board, Display
6	1	18854	Shield, Circuit Board
7	1	18283	Harness, Ribbon - 60 Pin
8	8	10342	Nut, Hex. #6-32
9	1	17877-XX	Circuit Board, Power (State Voltage And No. Of Relays Installed)
10	4	18292	Spacer, Stainless Steel
11	2	19367	Screw, Cover
12	1	18607-01	Enclosure
13	1	18760	Instruction, Label
14	2-3	17886-XX	Interlock Cable - Systemax (Specify Cable Length)
15	2-3	19011-XX	Interlock Cable - Systemax Environmental (Not Shown) (Specify Cable Length)
16	1	17995	Power Cord, US Systemax
17	1	19155	Fitting, Liquid Tight 1/2" NPT
18	1	17989	Housing, 3 Circuit (Not Shown)
19	0-1	18650	Seal, Knockout (Not Shown)
20	6-9	18839	Relay, 12VDC Plug-In (Not Shown)
21	2-3	19675	Holder, Fuse (Not Shown)
22	2-3	19676	Fuse, 6.3A 250V (Not Shown)
23	2-3	19709	Label, Fuse Holder - 6.3A (Not Shown)
24	1	19156	Nut, Liquid Tight, 1/2" NPT (Not Shown)

SYSTEMAX 2014

Standard 2500 / 2750 / 2850 / 3150 / 9000 / 9500 Valve Wiring

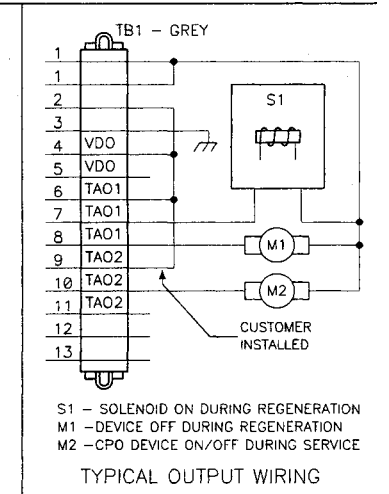
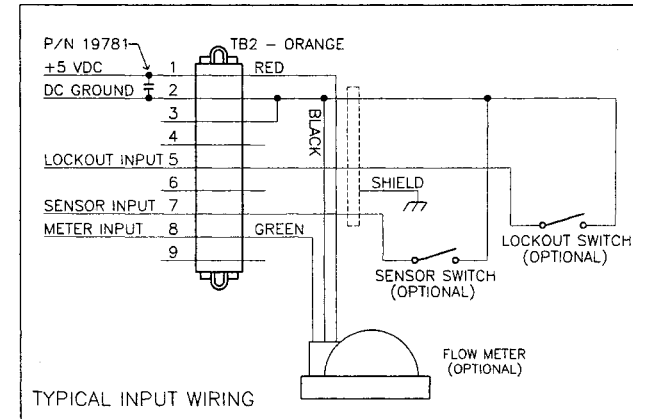
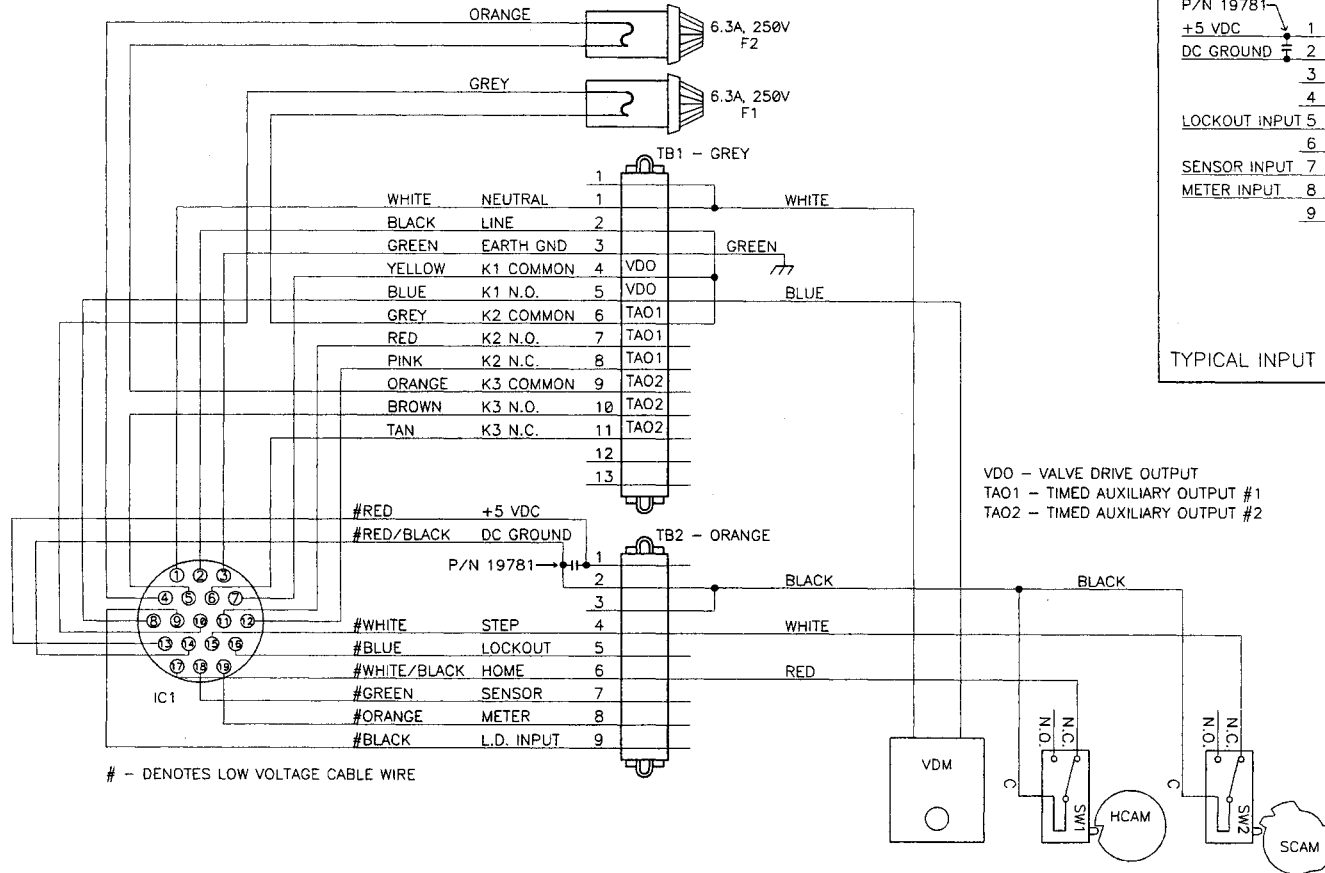

TB1 - HIGH VOLTAGE TERMINAL BLOCK
 TB2 - LOW VOLTAGE TERMINAL BLOCK
 IC1 - INTERLOCK CABLE RECEPTACLE
 F1 - TIMED AUXILIARY OUTPUT #1 FUSE
 F2 - TIMED AUXILIARY OUTPUT #2 FUSE
 VDM - VALVE DRIVE MOTOR
 HCAM - VALVE HOMING CAM
 SCAM - VALVE STEP CAM
 SW1 - VALVE HOMING SWITCH
 SW2 - VALVE STEP SWITCH

VDO - VALVE DRIVE OUTPUT
 TAO1 - TIMED AUXILIARY OUTPUT #1
 TAO2 - TIMED AUXILIARY OUTPUT #2

SYSTEMAX 2014

Standard 2900 / 3900 Valve Wiring

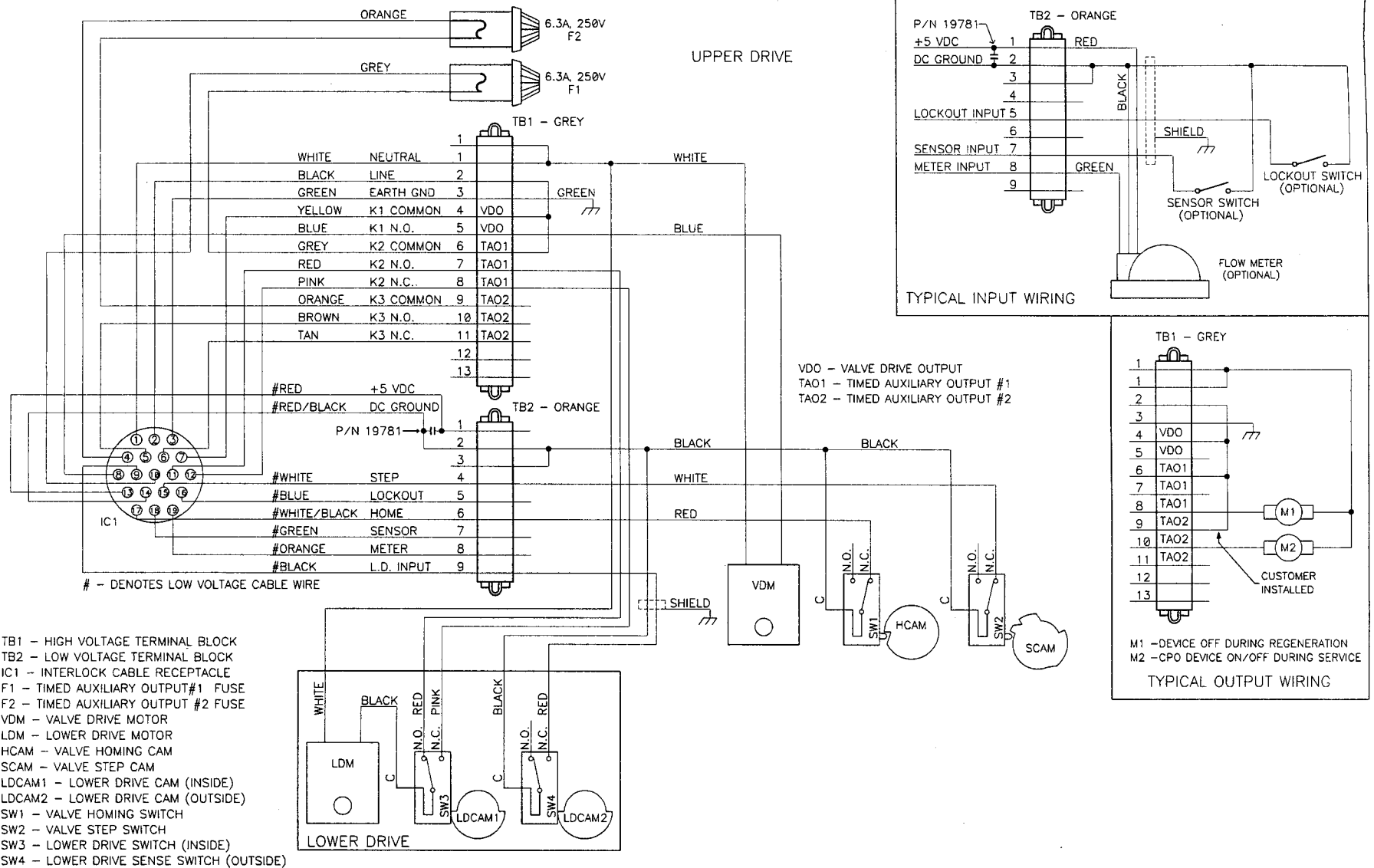

SYSTEMAX 2014

Standard Diaphragm Valve Stager Wiring

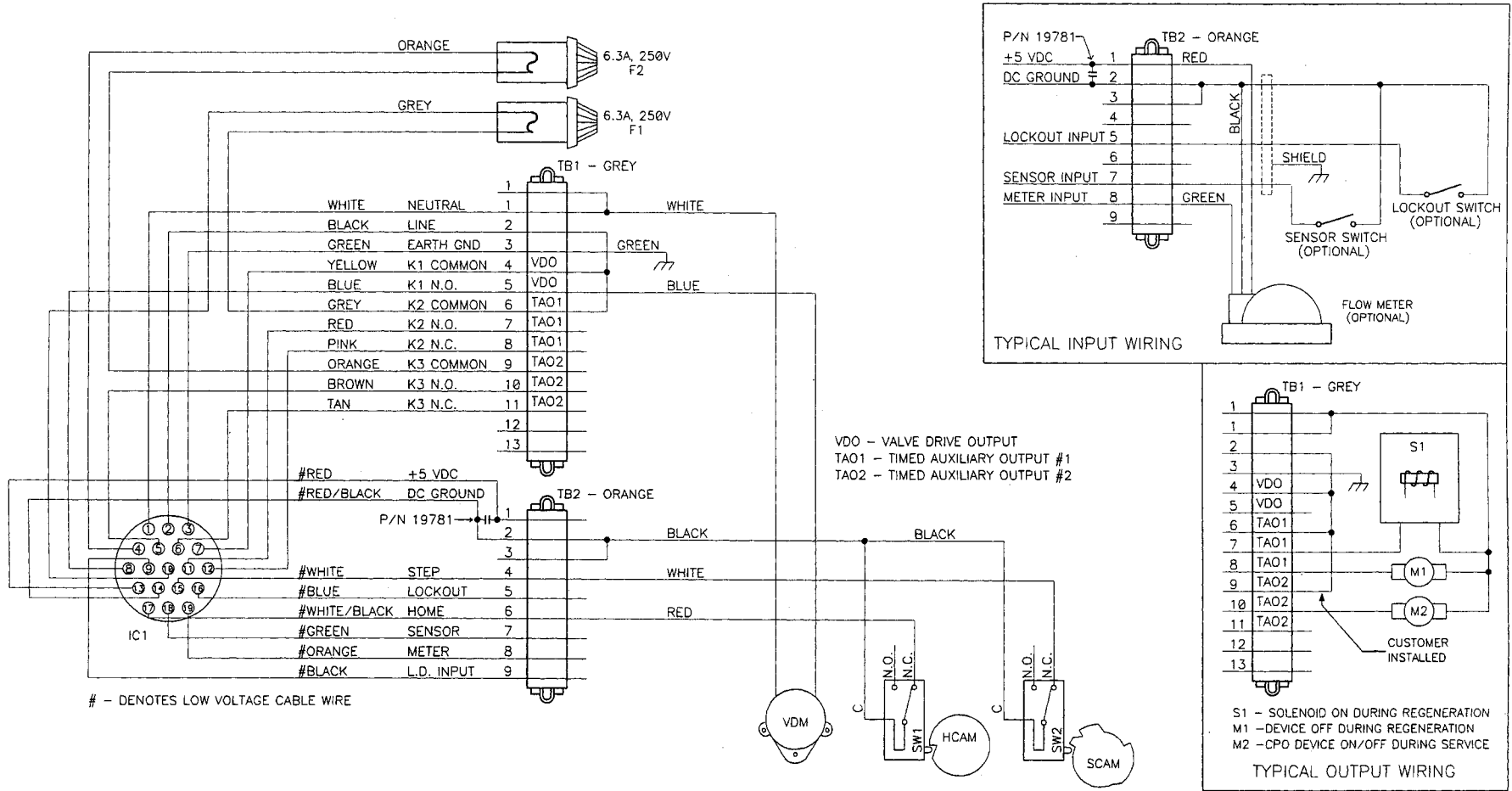

- TB1 - HIGH VOLTAGE TERMINAL BLOCK
- TB2 - LOW VOLTAGE TERMINAL BLOCK
- IC1 - INTERLOCK CABLE RECEPTACLE
- F1 - TIMED AUXILIARY OUTPUT #1 FUSE
- F2 - TIMED AUXILIARY OUTPUT #2 FUSE
- VDM - VALVE DRIVE MOTOR
- HCAM - VALVE HOMING CAM
- SCAM - VALVE STEP CAM
- SW1 - VALVE HOMING SWITCH
- SW2 - VALVE STEP SWITCH

- DENOTES LOW VOLTAGE CABLE WIRE

Controller Troubleshooting

1. No displays.
 - Check power cord connection and outlet circuit breaker.
 - Check controller and valve powerheads for water spray. If found, dry all electrical components before operating.
2. Dim displays.
 - Check voltage of outlet. It should be within +/- 10% of specified.
 - Check controller and valve powerheads for water spray. If found, dry all electrical components before operating.
3. Control locked up, displays function but never change.
 - Check controller and valve powerheads for water spray. If found, dry all electrical components before operating.
 - Push reset button located on the rear lower right-hand corner of the display circuit board. The controller will go immediately to Start Mode. No reprogramming will need to be done.
 - Or, unplug controller, remove battery from Battery Backup Pack, wait 10 seconds, plug in controller, reset time of day etc. and reinstall battery into pack. The controller will go immediately to Start Mode. No reprogramming will need to be done.
 - As a last resort, push and hold the system and Unit #3 Display Selector Buttons for 25 seconds. This will return the controller to the start Mode *and* reset all programming to their initial settings.
4. Control functions normally but valve sequencing appears to be wrong.
 - Check interlock cable routing - Unit #1 cable must go to Valve #1, #2 to #2, and #3 to #3.
 - Check that the Valve Type setting is correct.
5. Volume Remaining Display is below reserve or at zero but valve does not regenerate.
 - Check status displays of each unit for the following:
 1. A Regeneration lockout signal.
 2. Upper or Lower drive Input Signal Failure [**Ld Error**] or [**Ud Error**] on VFD, and a rapidly flashing Unit # Program Select Button.
 3. Another unit is in regeneration.
 4. Valve Drive Output LED On
 - If #1 was the problem, remove lockout signal.
 - If #2 was the problem, check valve wiring and microswitch plug connections then manually regenerate valve with Upper / Lower Drive Input failure. (The unit # with the rapidly flashing Program Select Button)
 - If #3 was the problem, wait until unit in regeneration returns to Standby or Service or step it through the remainder of its regeneration.
 - If #4 was the problem, check Valve Drive Relay for that unit on the power circuit board. Unplug and replace if bad. If good, check valve drive motor and replace if bad.
 - Check system and unit programming.
6. Adjacent VFD display segments or digits are on dimly when they should not be.
 - Dry out moisture on display circuit board.

Notes

Notes
